

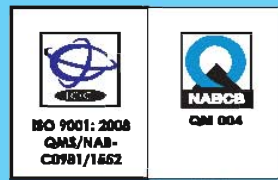

RUTTONSHA



An ISO 9001:2008 Company

RUTTONSHA

INTERNATIONAL RECTIFIER LIMITED

SHORT FORM CATALOGUE



**Leaders in
Semiconductor Devices
Power Rectifiers
Battery Chargers**

www.ruttonsha.com

An Operation for Years together.

A Story of SUCCESS...

- ☞ Ruttonsha International Rectifier Ltd. was incorporated in the year 1969 got listed on Bombay Stock Exchange (BSE) in the year 1992.
- ☞ We are today a Global Landmark in Semiconductors having more than two and a half decades of technological association with International Rectifier, USA, for the manufacturing of Power Semiconductors. The Company is having the ascendancy of IR Technology as well as access to Developmental & Technological expertise of Silicon Power Corporation, U.S.A (Ex General Electric Company). Silicon Power is into Power Process Solutions and today one of the World Leaders in Power Electronics.
- ☞ We have successfully implemented the Project of manufacturing High Power Semi Conductor Devices which has the Capacity to Manufacturer the products ranging upto 9000 volts and 6000 amperes.
- ☞ With an in house facility viz. Die Fabrication, Soldering, Encapsulation and Testing spread over a total built up area of over 40,000 Sq. Ft., near Vadodara, Gujarat, India, today we stand firm as one of the leading International players in Semi-conductor Industry.
- ☞ Our well diversified product range includes Bridges, Modules, Diodes ranging from 6 Amps to 5000 Amps and Thyristors ranging from 16 Amps to 6000 Amps with voltage group ranging up to 9000 V.
- ☞ We have the capacity to execute Bulk orders and have been successfully exporting to various parts of the world including U.S.A and Europe.
- ☞ Our Symbols of Goodwill include clientile both the Government and Semi-Government, Leading Private Organisations & Original Equipment Manufacturers, etc. across the nation and various parts of the world including the U.S.A, Europe, Middle East and countries like Malaysia, Turkey and many more. We have already got ourselves registered as approved suppliers with :-
 - ☞ Integral / Rail Coach Factories
 - ☞ DGQA (Ministry of Defence)
 - ☞ Nuclear Thermal Power Corporation
 - ☞ Naval Dockyard
 - ☞ Mormugao Port Trust
 - ☞ Indian Railways
- ☞ It has been our team's constant endeavour over the years to create a bond between us and our clients Globally.

● Rectifier Diode – Stud / Flat / Square Base	1
● Fast Recovery Rectifier Diode	1
● Phase Control Thyristor – Stud/Square Base	3
● Thyristor Inverter Grade – Stud	3
● Rectifier Diode – Capsule	5
● Rectifier Diode – Capsule for Welding Application	5
● Fast Recovery Rectifier Diode – Capsule	6
● Phase Control Thyristor – Capsule	7
● Inverter Thyristor – Capsule	8
● Power Module – Diode / Diode	9
● High Voltage Module - Diode / Diode	9
● Non-Isolated Three Thyristor Module	9
● Power Module – Thyristor / Thyristor	10
● Power Module – Thyristor / Diode	10
● High Voltage Module - Thyristor / Thyristor	10
● High Voltage Module - Thyristor / Diode	10
● Single Phase Diode Bridge	12
● Three Phase Diode Bridge	12
● Ultra Fast Diode Module	12
● Single Phase Diode Module	13
● Single Phase Half Controlled Module Bridge	13
● Three Phase Diode Bridge Module	14
● Thyristor Stack	15
● Diode Stack	15
● Welding Rectifier – Button Diode – Plate Type	16
● Water Cooled Assembly – Capsule SCR	17
● Isolated Water Cooled Module Assembly	18
● IGBT Stack	19

RECTIFIER DIODE - STUD / FLAT / SQUARE BASE TYPE

Type	V^{RRM}	IFAV@TC		IR	I_{FSM}	VFM @ IFM		V_o r_T		Tj max	R_{thJC}	R_{thcs}	Fig No.
	V	A	°C	mA	A	V	A	V	mΩ	°C	°C/W	°C/W	
12FM/FMR	400-1600	12	140	1.0	250	1.3	37	0.800	6.8	175	2	0.6	1
16FM/FMR	400-1600	16	140	1.0	300	1.2	50	0.800	6.8	175	1.6	0.6	1
25FM/FMR	400-1600	25	120	4.0	356	1.3	78	0.800	6.8	175	1.5	0.5	1
25HM/HMR	400-1600	25	140	5	400	1.35	78	0.860	3.0	175	1.5	0.5	2A, 2B
40HM/HMR	400-1600	40	140	5	500	1.35	125	0.690	3.7	175	1	0.5	2A, 2B
61HM/HMR	400-1600	60	140	5	860	1.35	188	0.790	2.33	175	0.55	0.25	3A, 3B
70HM/HMR	400-1600	70	140	5	1000	1.35	220	0.790	2.33	175	0.5	0.25	3A, 3B
100LM/LMR/LF/LFR	400-1600	100	130	15	2300	1.4	314	0.760	1.41	175	0.4	0.1/0.07	4A, 4B
150LM/LM R/LF/LFR	400-1600	150	130	15	3600	1.4	471	0.760	1.41	175	0.25	0.1/0.07	4A, 4B
200LM/LM R/LF/LFR	400-1600	200	125	15	4400	1.4	628	0.850	0.85	175	0.17	0.08	4A, 4B
200UM/UMR/UF/UFR	400-1600	200	130	20	4300	1.35	628	0.850	0.85	175	0.2	0.08/0.05	5A, 5B
250UM/UMR/UF/UFR	400-1600	250	130	20	4500	1.3	785	0.760	0.55	175	0.18	0.08/0.05	5A, 5B
300UM/UMR/UF/UFR	400-1600	300	130	20	5000	1.4	942	0.760	0.55	175	0.12	0.08/0.05	5A, 5B
320UM/UMR/UF/UFR	400-1600	320	130	20	5500	1.4	1005	0.860	0.15	175	0.12	0.08/0.02	5A, 5B
350UF/UFR	400-1600	350	125	20	6000	1.2	1050	0.860	0.15	175	0.15	0.02	5B
321UM/UMR/UF/UFR	400-2700	320	130	20	5500	1.65	1005	0.720	0.53	175	0.12	0.08/0.02	6, 5C
351/352UF/UFR	400-1600	351	125	20	6000	1.2	1050	0.860	0.15	175	0.15	0.02	5C/5D
400UM/UMR/UF/UFR	400-2400	400	120	20	8250	1.62	1500	0.800	0.55	175	0.11	0.04	5A,5B
450V/VR/VF/VFR	200-2000	450	75	35	7500	1.66	1000	0.880	0.78	175	0.11	0.04	7A, 7B
600V/VR/VF/VFR	400-2000	600	92	35	13000	1.31	1500	0.780	0.35	175	0.1	0.04	7A,7B

FAST RECOVERY RECTIFIER DIODE

Type	V^{RRM}	IFAV@TC		I_{FSM}	VFM @ IFM		Reverse Recovery Time			V_o r_T		Tj max	R_{thJC}	R_{thcs}	Fig No.
	V	A	°C	A	V	A	t_r	$@I_{FM}$	di/dt	V	mΩ	°C	°C/W	°C/W	
							nS	A	A/μS						
12FL/FLR	100-1000	12	100	145	1.4	38	500	1	25	1.2	35	150	2	0.5	1
16FL/FLR	100-1000	16	100	180	1.4	50	500	1	25	1.200	20	150	1.6	0.5	1
40HFL/HFLR	100-1000	40	75	400	1.95	125	500	1	100	1.080	20	150	0.6	0.25	2A, 2B
70HFL/HFLR	100-1000	70	75	700	1.85	220	500	1	100	1.085	10	150	0.36	0.25	3A, 3B
100LML/LMLR	100-1000	100	75	1800	1.6	314	500	350	25	1.360	2.55	150	0.35	0.15	4A
150LML/LMLR	100-1000	150	75	2850	1.55	471	500	350	25	1.000	4.00	150	0.2	0.15	4A
200LML/LMLR	200-600	200	125	3650	1.55	628	500	350	25	1.00	1.1	150	0.1	0.07	4A

SILICON RECTIFIERS

PHYSICAL DIMENSIONS

All Dimension are in mm.

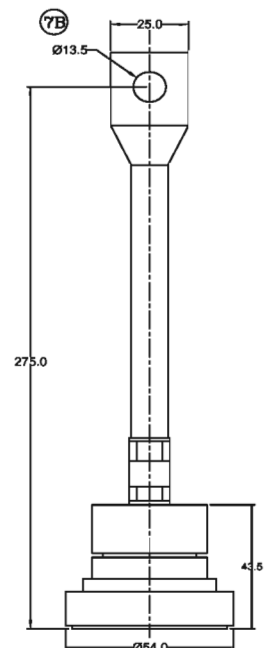
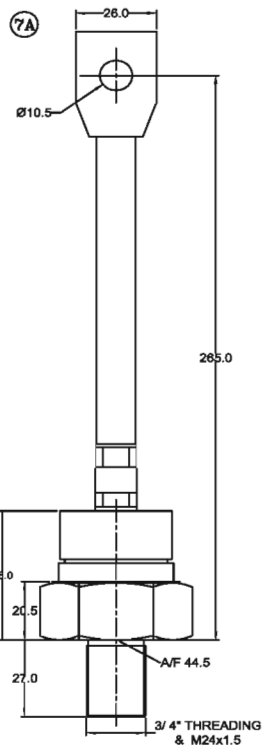
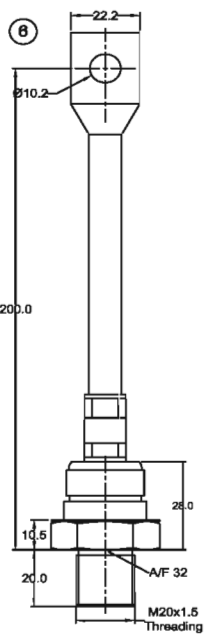
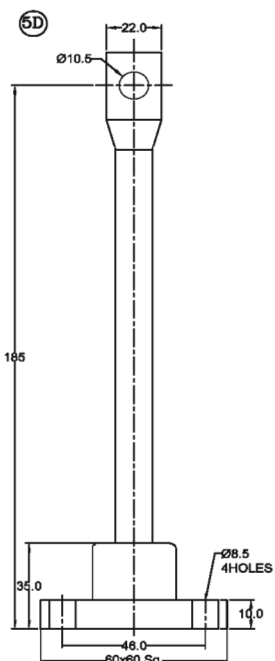
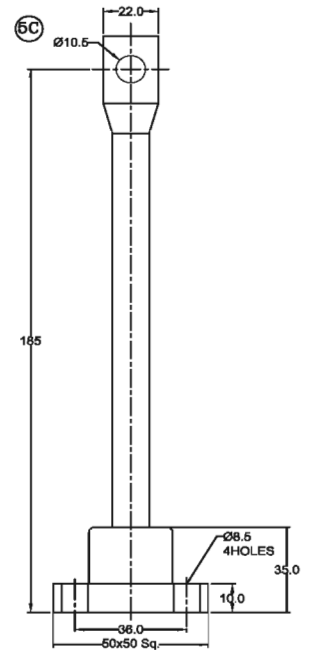
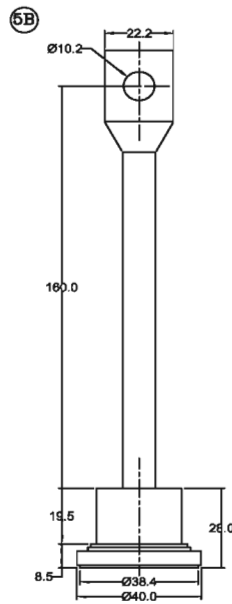
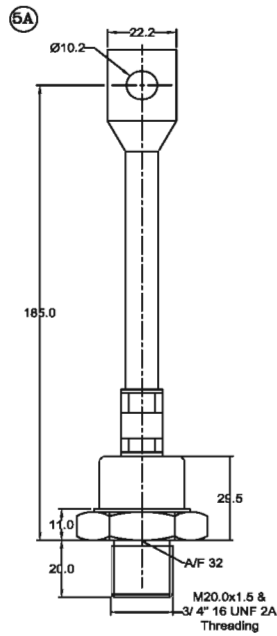
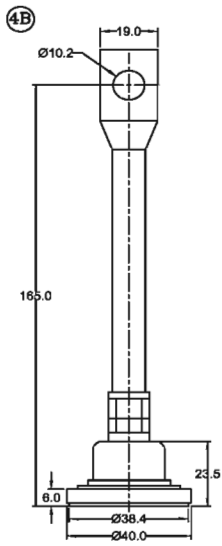
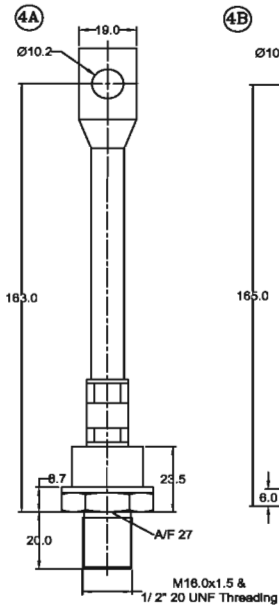
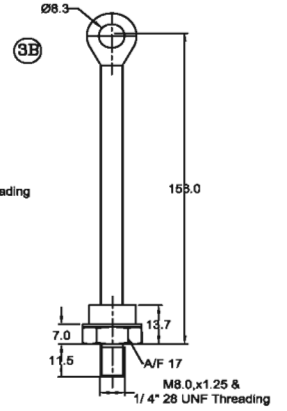
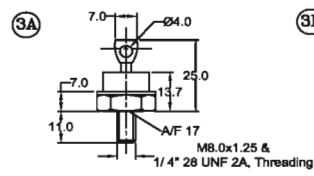
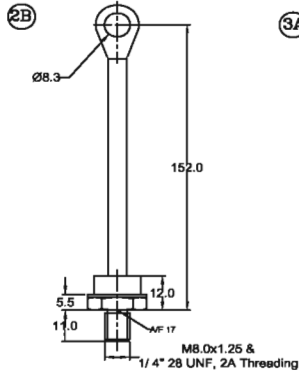
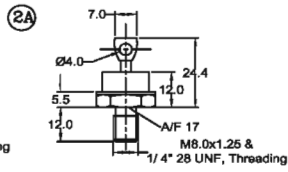
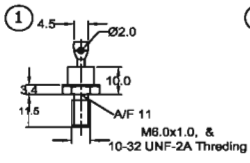

PHASE CONTROL THYRISTOR - STUD/SQUARE BASE TYPE

Type	V _{DRM} V _{RRM}	I _{T(AV)}	@T _C	I _{TSM}	V _{TM} @I _{TM}		V _{TO}	r _T	IGT	VGT	dv/dt	di/dt	R _{thJC}	R _{thCS}	Fig.
				V	A	°C	A	V	A	V	mΩ	mA	V	V / μs	
16RIA	100-1600	16	85	285	1.75	50	0.99	11.73	60	2.0	300	100	1.15	0.35	1
25RIA	100-1600	25	85	350	1.70	78	0.99	11.73	60	2.0	300	100	0.75	0.35	1
41RIA	100-1600	40	94	1050	1.65	125	1.02	4.78	100	2.5	500	100	0.40	0.25	2
51RIA	100-1600	50	94	1200	1.60	157	1.02	4.78	100	2.5	500	100	0.35	0.25	2
71RIA	100-1600	70	80	1200	1.80	220	0.97	4.10	100	2.5	500	100	0.35	0.10	3
81RIA	100-1600	80	85	1597	1.60	251	0.85	3.50	3	2.5	500	100	0.30	0.10	3
81RK	100-1600	80	90	1730	1.80	251	1.21	2.40	150	3.0	500	100	0.26	0.08	4
111RK	100-1600	110	90	2270	1.52	350	0.90	1.79	150	3.0	500	100	0.20	0.08	4
125RK	200-1600	125	85	2570	1.55	400	0.90	1.79	150	3.0	500	100	0.19	0.08	4
155RK	200-1600	150	90	2700	1.80	471	1.14	1.70	150	3.0	500	100	0.11	0.04	5
175RK	200-1600	170	85	3900	1.75	533	1.08	1.80	150	3.0	500	100	0.105	0.04	5
280RK	200-600	280	85	6600	1.28	880	0.84	0.50	150	3.0	500	100	0.105	0.04	5
235RK	200-1600	230	85	4800	1.55	722	0.92	0.81	150	3.0	500	100	0.10	0.04	5
255RK	200-1600	250	75	5570	1.90	785	0.98	0.95	200	3.0	500	100	0.105	0.03	6
305RK	200-1600	300	75	6730	1.66	942	0.97	0.74	200	3.0	500	100	0.10	0.03	6
355RK	200-1600	350	75	7550	1.55	1099	0.91	0.80	200	3.0	500	100	0.08	0.03	6/7
380RK	200-600	380	75	10500	1.40	1193	0.91	0.58	200	3.0	500	100	0.08	0.03	6/7
400RK	200-1600	400	75	9500	1.55	1255	0.90	0.40	200	3.0	500	100	0.10	0.03	7
450RKS	200-1600	450	85	11500	1.66	1400	1.05	0.20	200	3.0	500	100	0.073	0.01	7
500RKS	200-1600	500	85	12000	1.60	1570	1.06	0.02	250	3.0	500	100	0.073	0.01	7

THYRISTOR INVERTER GRADE - STUD TYPE

Type	V _{DRM} V _{RRM}	I _{TAV}	TC	I _{T(RMS)}	I _{TSM} 10ms	V _{TM} @I _{TM}		Turn-off @I _{TM} & di / dt			V _{TO}	r _T	IGT	VGT	dv/dt	di/dt	R _{thJS}	R _{thCS}	Fig.
								t _q											
						V	A	°C	A	A	V	A	μs	A	A / μs	V	mΩ	mA	
41RIA..F	100-1200	40	94	63	700	2.40	125	40	50	10	1	7.9	100	2.5	500	100	0.400	0.250	2
51RIA..F	100-1200	50	94	79	1000	2.00	157	40	50	10	1.00	7.00	100	2.5	500	100	0.350	0.250	2
85RK..F	400-1200	85	85	134	2450	2.15	300	10 to 30	300	20	1.46	4	200	3.0	500	100	0.195	0.080	4
175RK..F	400-1200	175	85	275	4680	2.07	600	15 to 25	300	20	1.55	0.870	200	3.0	500	100	0.105	0.040	5
205RK..F	400-1200	205	85	320	5260	1.72	600	20 to 30	300	20	1.17	0.92	200	3.0	500	100	0.105	0.040	5
300RK..F	400-1200	300	65	471	7950	2.16	1225	10 to 30	550	40	1.44	0.57	200	3.0	500	100	0.100	0.030	6



PHASE CONTROL THYRISTOR - STUD/SQUARE BASE TYPE

PHYSICAL DIMENSIONS

All Dimension are in mm.

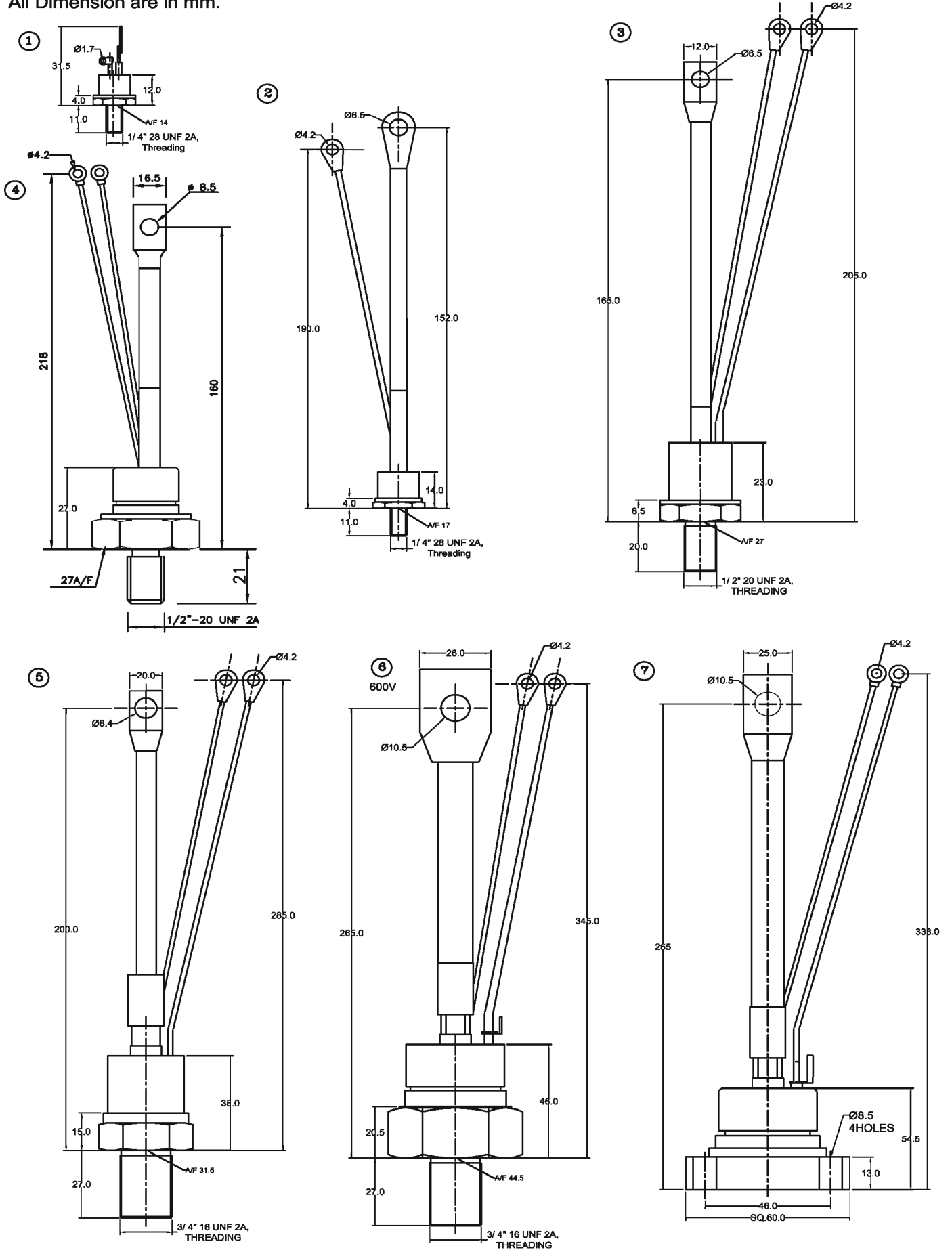

RECTIFIER DIODE - CAPSULE TYPE

Type	V^{RRM}	IFAV @TC		I_{FSM}	VFM@IFM		V_0	r_T	T_j max	R_{thJ-hs}	Fig.No.
	V	A	°C	A	Tj = Tj max		@Tj max				
					10ms	V	A	V	mΩ	°C	
R450A..C	200-1600	450	95	6050	1.80	1500	0.850	0.70	160	0.090	1
R650A..C	200-1600	650	55	6050	2.08	1500	0.950	0.75	180	0.090	1
R800A..C	200-1600	800	55	8250	1.86	1930	0.800	0.55	190	0.090	1
R920E...C	2600-3400	920	55	5600	1.38	1000	0.700	0.70	160	0.050	2
R1100E..C	200-1600	1100	55	10500	1.44	1500	0.840	0.40	160	0.050	2
R1200E..C	200-1600	1220	55	10500	1.44	1500	0.840	0.60	180	0.038	2
R1400E..C	200-1600	1400	55	13000	1.31	1500	0.780	0.35	160	0.038	2
R1600E..C	200-800	1600	55	16000	1.55	3000	0.750	0.25	160	0.038	2
R750B..C	3200-4400	750	85	10000	1.45	1000	0.800	1.00	160	0.037	3
R1200B..C	400-3600	1180	55	13600	1.66	2000	0.900	0.70	160	0.031	3
R1300B..C	400-2600	1300	55	15000	1.60	4000	0.860	0.50	160	0.033	3
R1600B..C	2000-3000	1600	55	16600	1.64	3000	0.830	0.43	180	0.031	3
R2000B...C	200-2000	2000	55	16600	1.64	3000	0.830	0.24	180	0.031	3
R900K..C	4000-6000	900	60	9200	1.76	1000	1.150	1.70	160	0.023	4
R1700K..C	3200-4200	1700	55	22000	1.15	1000	1.150	0.36	160	0.023	4
R1800K..C	400-3000	1800	55	25000	1.65	3800	0.850	0.37	160	0.023	4
R2000K..C	2000-4500	2080	55	20200	1.81	4000	0.890	0.33	160	0.020	4
R3000K..C	1200-2500	3000	55	31000	1.41	4000	0.760	0.13	160	0.020	4
R3200K..C	800-2200	3270	55	30400	1.47	6000	0.730	0.12	175	0.022	4
R4500K..C	300-600	4540	55	44000	1.02	3000	0.760	0.03	160	0.022	4
R2000L/M..C	5000-6000	2000	55	21800	1.45	3000	0.960	0.42	160	0.017	5,6
R4500L/M..C	200-1400	4500	55	52000	1.05	4000	0.650	0.07	160	0.016	5,6
R4950Q/R..C	1600-3000	4950	55	60000	1.01	2000	0.800	0.10	175	0.012	7,8
R5000S..C	4500-5000	5000	55	55000	1.20	2000	0.800	0.18	160	0.007	9

RECTIFIER DIODE - CAPSULE TYPE FOR WELDING APPLICATION

R4000G..C	200-600	3200	85	60000	0.95	4000	0.70	0.04	180	0.030	10
R6000G..C	200-600	6000	85	60000	0.95	4000	0.70	0.04	180	0.030	10
R12000T..C	400-600	12000	55	85000	0.87	4500	0.70	0.15	180	0.0095	11
R12000TC..C	400-600	12000	55	85000	0.87	4500	0.70	0.15	180	0.0095	12



FAST RECOVERY RECTIFIER DIODE - CAPSULE TYPE

Type	V _{RRM}	I _{FAV} @55°C	I _{FSM} 10mS	V _F at I _F @T _j max		Reverse Recovery Time			V _o	r	T _{jmax}	R _{thJ-hs}	Fig.
						t _{rr}	@I _{FM}	di/dt					
V	A	A	V	A	μS	A	A / μS	V	mΩ	°C	°C/W		
R430A..F	400-2500	430	5770	2.25	1100	2.9	750	25	1.14	0.90	125	0.080	1
R600E..F	400-2200	600	8320	2.97	1885	3.2	1000	25	1.36	0.70	125	0.050	2
R760E..F	400-1600	760	9000	1.70	1500	2.0	550	40	1.13	0.40	125	0.050	2
R920B..F	1800-3000	920	13000	2.26	1500	4.5	1000	100	1.51	0.80	150	0.031	3
R1000B..F	1800-3000	1000	14000	1.90	1000	4.5	1000	100	1.51	0.45	150	0.037	3
R990K..F	3000-4500	990	19000	2.90	2000	5	1000	100	1.50	0.80	125	0.020	4
R1200K..F	1700-3000	1200	20000	1.75	1000	4	1000	100	1.15	0.80	150	0.023	4
R1500K..F	1700-2500	1500	21560	2.10	4000	5	1000	60	1.15	0.265	125	0.022	4
R1650K..F	1800-3000	1650	22000	2.60	4000	5	1000	100	1.31	0.400	150	0.020	4
R2000L..F	2000-4500	1995	23600	2.95	2100	7	1000	100	2.35	0.265	150	0.013	5
R2800M..F	1800-2500	2837	35000	1.41	3000	7	1000	60	0.90	0.170	150	0.016	6
R3000Q..F	1600-2400	3000	31800	1.50	3000	7	1000	60	0.90	0.240	150	0.012	7
R3200Q..F	3000-4500	3230	20000	2.00	3000	7	1000	100	1.25	0.150	150	0.012	7

CAPSULE DIODE

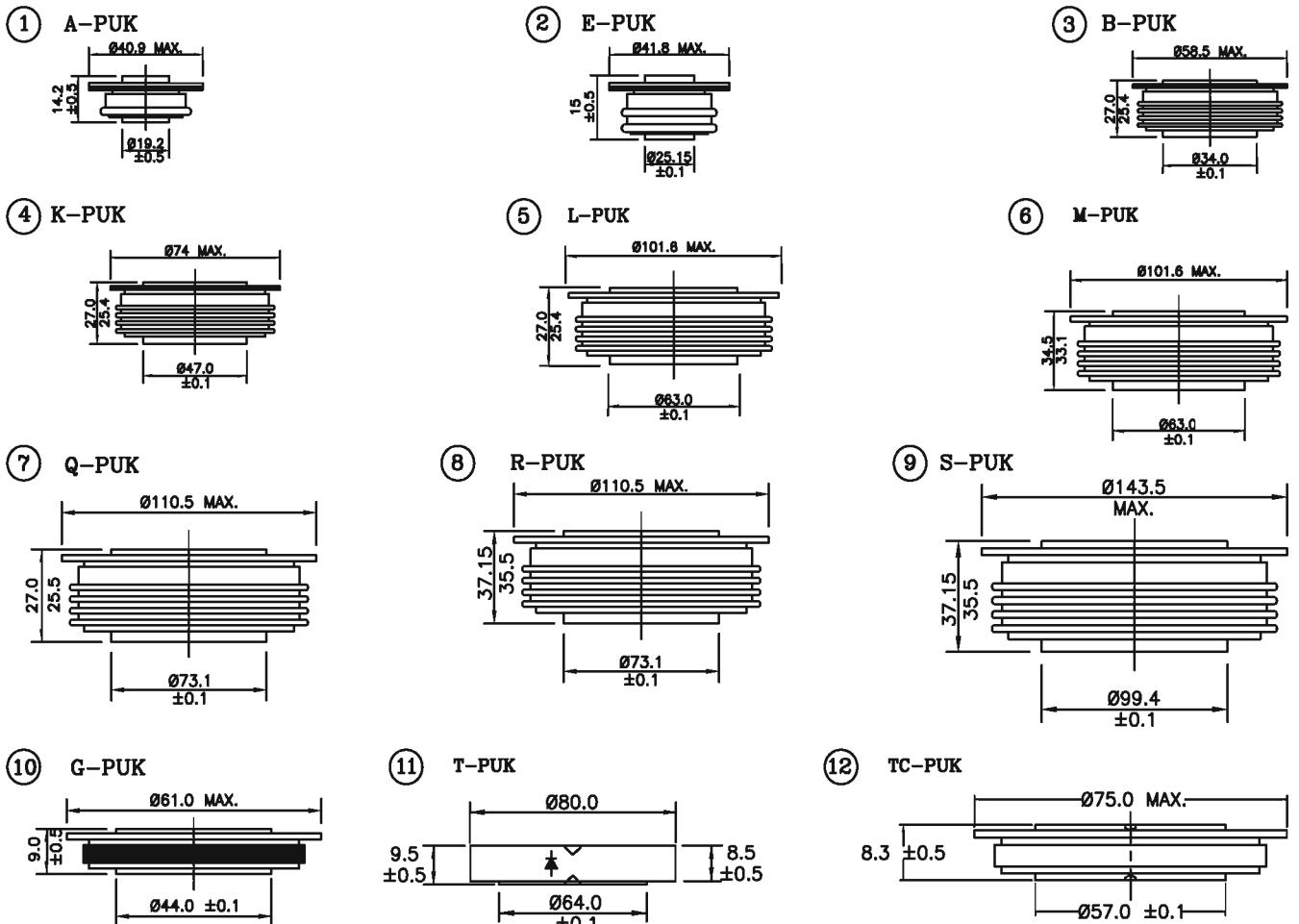

ALL DIMENSIONS ARE IN mm.

PHASE CONTROL THYRISTOR - CAPSULE TYPE

Type	V_{DRM} V_{RRM}	$I_{T(AV)}$	$@T_C$	I_{TSM} 10ms	$V_{TM}@I_{TM}$		V_{TO}	r_T	IGT	VGT	dv/dt	di/dt	R_{th-hs}	Fig.
	V	A	°C	A	V	A	V	mΩ	mA	V	V / μs	A / μs	K/W	
340PA	1200-1800	323	85	5700	1.90	1000	1.00	0.85	150	3.0	500	100	0.074	1
400PA	200-1700	410	55	5700	1.69	880	0.92	1.21	150	3.0	500	100	0.080	1
450PA	200-1700	450	55	5700	1.69	880	0.92	0.92	150	3.0	500	100	0.080	1
500PA	200-1200	500	55	7850	1.36	1050	0.84	0.74	150	3.0	500	100	0.080	1
550PE	800-1600	550	85	9000	1.65	1500	0.93	0.40	200	3.0	500	100	0.050	2
600PE	200-1600	650	55	9000	1.90	1730	0.91	0.78	200	3.0	500	100	0.050	2
600PE	1500-3000	600	55	7500	2.10	1500	1.14	0.80	200	3.0	500	100	0.050	2
700PE	400-2200	720	55	9000	1.96	1810	0.91	0.85	200	3.0	500	100	0.040	2
900PE	200-600	960	55	15000	1.60	3000	0.85	0.41	200	3.0	500	100	0.040	2
750PB	2500-4500	750	55	5100	2.20	500	1.04	0.70	200	3.0	500	100	0.040	3
760PB	800-1600	760	83	13000	1.65	2400	0.92	0.25	200	3.0	500	100	0.040	3
900PB	1200-2200	910	55	15700	1.80	2000	1.00	0.66	200	3.0	500	100	0.031	3
1000PB	400-1800	1000	55	17800	1.62	2000	0.98	0.52	200	3.0	500	100	0.031	3
1200PB	400-1200	1200	55	17800	1.55	2000	1.06	0.28	200	3.0	500	100	0.031	3
1300PB	400-600	1350	55	24400	1.31	3600	0.80	0.26	200	3.0	500	100	0.031	3
550PK	5500-7000	550	70	5500	2.00	500	1.30	2.00	200	3.0	500	100	0.025	4
800PK	4100-4500	800	70	8000	2.00	1000	1.14	0.80	200	3.0	500	100	0.025	4
1160PK	3400-4200	1160	55	14500	2.15	1830	1.10	0.45	250	3.0	500	100	0.025	4
1300PK	2800-3600	1300	55	18000	1.70	1000	1.10	0.40	250	3.0	500	100	0.023	4
1400PK	1200-2800	1473	55	20000	1.80	3000	0.95	0.28	250	3.0	500	100	0.024	4
1450PK	1200-2400	1450	55	19400	1.30	1000	1.00	0.28	250	3.0	500	100	0.024	4
1500PK	2000-3000	1500	55	23600	1.30	1000	1.02	0.25	250	3.0	500	100	0.024	4
1650PK	1200-2400	1650	55	20000	1.73	4000	0.91	0.21	250	3.0	500	100	0.024	4
1700PK	600-2200	1745	55	33500	1.85	4000	0.93	0.17	250	3.0	500	100	0.024	4
1950PK	800-1600	1950	55	26250	1.40	3000	0.94	0.12	250	3.0	500	100	0.024	4
2000PK	400-1800	2000	58	36000	1.40	3000	0.82	0.12	250	3.0	500	100	0.024	4
2200PK	200-600	2310	55	42500	1.44	4000	0.83	0.11	250	3.0	500	100	0.021	4
2500PK	200-800	2500	55	42500	1.25	4000	0.83	0.08	250	3.0	500	100	0.021	4
1500PL/PM	1600-3800	1500	55	25000	2.17	3200	1.04	0.45	250	3.0	500	100	0.017	5,6
1650PL/PM	1600-3600	1650	55	25000	2.17	3200	1.04	0.36	250	3.0	500	100	0.017	5,6
1660PL/PM	3000-3600	1660	55	23000	2.17	3220	1.04	0.35	250	3.0	500	100	0.017	5,6
1700PL/PM	2400-3000	1700	55	30000	2.08	3220	1.05	0.33	250	3.0	500	100	0.017	5,6
2200PL/PM	1200-2000	2200	55	26400	1.70	4000	0.96	0.17	250	3.0	500	100	0.017	5,6
2500PL/PM	1200-1800	2500	55	37000	1.20	2000	0.88	0.12	250	3.0	500	100	0.017	5,6
2000PQ/PR	3500-4500	2000	55	24400	1.85	2000	1.35	0.32	250	3.0	500	100	0.012	7,8
2200PQ/PR	2800-3800	2200	55	27000	1.71	2000	1.16	0.28	250	3.0	500	100	0.012	7,8
2400PQ/PR	1800-2800	2400	55	32800	1.35	2000	0.78	0.28	250	3.0	500	100	0.012	7,8
2500PQ/PR	2400-3600	2500	55	27000	1.71	2000	1.06	0.25	250	3.0	500	100	0.011	7,8
2800PQ/PR	1800-3600	2824	55	40000	1.87	4000	0.97	0.16	250	3.0	500	100	0.012	7,8
3000PQ/PR	2000-3500	3000	55	52000	1.55	2000	0.88	0.14	250	3.0	500	100	0.012	7,8
4000PQ/PR	600-1400	4000	55	60000	1.10	3000	0.85	0.06	250	3.0	500	100	0.012	7,8
3500PQ	3000-4200	3476	55	52000	1.87	5000	0.97	0.18	300	3.0	500	100	0.008	9
2500PU	3500-4500	2500	55	24400	1.85	2000	1.35	0.35	300	3.0	500	100	0.008	9
3000PU	4500-5200	2960	55	36000	2.10	4000	1.23	0.24	300	3.0	500	100	0.008	9
3500PU	2200-3200	3476	55	52000	1.87	5000	0.97	0.18	300	3.0	500	100	0.008	9
3740PU	2200-2800	3740	70	60000	1.23	3000	0.95	0.10	300	3.0	500	100	0.008	9
4400PU	2000-3200	4400	55	64000	1.40	4000	0.90	0.10	300	3.0	500	100	0.008	9
3000PS	3000-5200	3000	55	54000	1.70	3000	0.81	0.34	300	3.0	500	100	0.007	10
3700PS	4500-5000	3700	55	50000	2.00	4000	1.00	0.19	300	3.5	500	100	0.007	10
3900PS	3500-4500	3900	55	37500	1.90	2000	1.15	0.15	300	4.0	500	100	0.007	10
4400PS	2700-3200	4400	55	56000	1.50	4000	0.94	0.12	300	4.0	500	100	0.007	10
5000PS	1600-2800	5000	55	60000	1.30	4000	0.94	0.09	300	5.0	500	100	0.007	10

Note: dv/dt 1000V/μs is available on request.

THYRISTOR INVERTER GRADE - CAPSULE TYPE

Type	V_{DRM} V_{RRM}	I_{TAV}	TC	I_{TSM}	VTM@ITM		Turn-off Time t_q	$@I_{TM}$	di / dt	$@ T_J = 125^\circ C$		IGT	VGT	dv/dt	di/dt	Rth _{JS}	Fig.
	V	A	°C	A	V	A				V_{TO}	r_T						
330PA..F	200-1200	330	55	4680	2.07	600	15-30	300	20	1.55	1.30	150	3.0	500	100	0.080	1
370PA..F	200-1200	370	55	4900	1.80	600	10-20	300	20	1.40	0.99	150	3.0	500	100	0.080	1
620PE..F	200-1200	620	55	7950	2.16	1255	10-30	300	20	1.44	0.94	150	3.0	500	100	0.040	2
750PB..F	800-1400	750	55	9000	2.21	1000	55	1000	25	1.03	0.70	150	3.0	500	100	0.040	3
930PB..F	800-1200	930	55	9000	2.90	2000	25	1000	60	1.50	0.15	150	3.0	500	100	0.040	3
1050PK..F	1400-2000	1050	55	12000	2.10	1000	40-45	1000	25	1.57	0.40	200	3.0	500	100	0.025	4
1125PK..F	1400-2000	1125	65	20000	2.10	1000	30-50	1000	25	1.54	0.258	200	3.0	500	100	0.023	4
1200PK..F	1400-2100	1200	55	13000	1.70	1000	40-60	1000	25	1.31	0.35	200	3.0	500	100	0.025	4
1350PK..F	1400-2100	1350	65	20000	1.45	1000	40-60	1000	25	1.20	0.23	200	3.0	500	100	0.023	4
1450PK..F	600-1200	1446	55	20000	1.70	2000	20-35	1000	60	1.30	0.22	200	3.0	500	100	0.023	4
2600PR..F	1400-2500	2600	55	38000	1.55	2000	60-80	1000	25	1.31	0.14	200	3.0	500	100	0.012	8
3300PR..F	600-1200	3370	55	43900	1.54	4000	15-25	4000	60	1.35	0.064	200	3.0	500	100	0.011	8

CAPSULE THYRISTOR

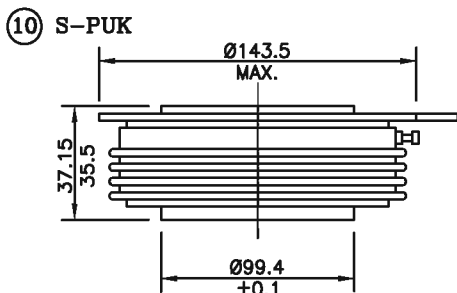
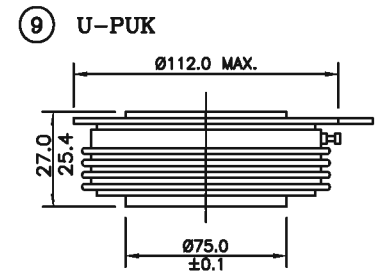
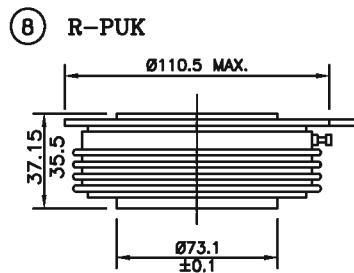
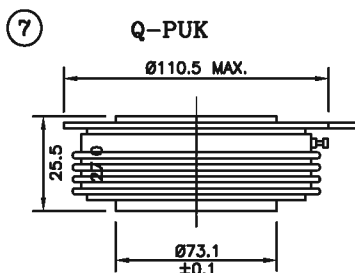
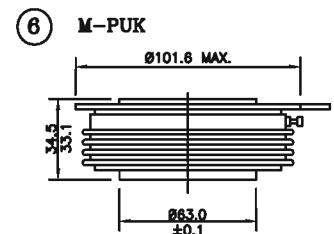
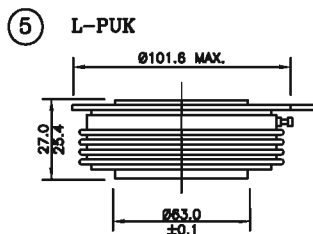
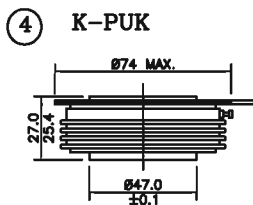
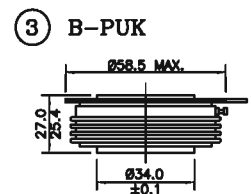
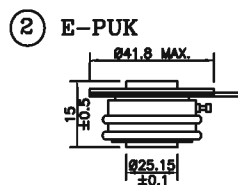
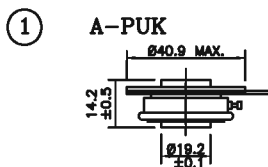

ALL DIMENSIONS ARE IN mm.

POWER MODULES - DIODE / DIODE

Type No.	I _{F(AV)}	@T _C	V _{RRM} RANGE	I _{FSM}	V _{FM}	@I _{FM}	V ₀	r	R _{th} JC	R _{th} CS	T _J Max	Ref.Fig.
				10ms			T _J = T _J max					
	A	°C	V	A	V	A	V	mΩ	°C/W	°C/W	°C	
IRK-41	40	85	400 to 1600	850	1.65	126	0.88	5.90	0.230	0.100	135	1
IRK-56	55	100	400 to 1600	1600	1.35	173	0.71	3.76	0.325	0.100	135	1
IRK-71	70	100	400 to 1600	1790	1.30	220	0.61	2.80	0.285	0.100	135	1
IRK-91	90	100	400 to 1600	2020	1.30	283	0.66	1.81	0.220	0.100	135	1
IRK-105	105	87	400 to 1600	2020	1.34	330	0.66	1.81	0.220	0.100	135	1
IRK-166	165	100	400 to 1600	4000	1.57	518	0.70	1.69	0.200	0.035	135	2
IRK-196	195	100	400 to 1600	4750	1.32	612	0.75	0.92	0.200	0.035	135	2
IRK-236	230	100	400 to 1600	6540	1.26	722	0.79	0.64	0.170	0.035	135	2
IRK-250	250	100	400 to 1600	7015	1.29	785	0.79	0.63	0.160	0.020	135	3
IRK-270	270	100	400 to 1600	8920	1.48	848	0.74	0.94	0.125	0.020	135	3
IRK-320	320	100	400 to 1600	10110	1.28	1005	0.69	0.59	0.125	0.020	135	3
IRK-350	350	100	400 to 1600	10110	1.25	1100	0.69	0.59	0.125	0.035	135	3
IRK-570	570	100	1200 to 2800	15000	1.30	1700	0.80	0.38	0.065	0.020	135	4
IRK-700	701	100	1200 to 2200	22500	1.30	2000	0.70	0.15	0.072	0.020	135	4
IRK-1000	1000	100	400 to 1600	31000	1.41	4000	0.85	0.15	0.042	0.020	135	5
IRK-95F	95	75	400 to 600	1080	2.05	300	1.01	3.5	0.450	0.550	125	1
IRK-196F	195	100	400 to 600	4750	1.65	612	0.75	0.92	0.200	0.035	125	2

HIGH VOLTAGE DIODE / DIODE MODULES

IRK231	230	100	1400-2600	7015	1.29	722	0.79	0.63	0.160	0.035	135	3
IRK320	320	100	4600-6500	7000	2.40	1570	0.95	1.10	0.068	0.020	135	4
IRK435	435	85	3000-4200	12000	2.30	2100	0.85	0.33	0.065	0.020	135	4

POWER MODULES - NON-ISOLATED (3 THYRISTOR)

Type No.	I _{T(AV)}	@T _C	I _{RMS}	V _{RRM}	I _{TSM}	I ² t	V _{TM}	@I _{TM}	V _{GT}	I _{GT}	dv/dt	di/dt	R _{th} JC	T _J Max.	Ref.Fig.
					10ms										
	A	°C	A	V	A	A²Sec.	V	A	V	mA	V/μSec	A/μSec	°C/W	°C	
RHTT60A40	60	123	94	400	1640	13500	1.25	180	2.0	150	50	50	0.35	150	6
RHTT80A40	80	116	125	400	2280	26000	1.20	240	2.0	150	50	50	0.35	150	6
RHTT100A40	100	114	157	400	3200	51000	1.20	314	2.0	150	50	50	0.30	150	6
RHTT130A40	130	112	204	400	3200	51000	1.20	410	2.0	150	50	50	0.20	150	6
RHTT200A40	200	121	314	400	5400	1499400	1.20	630	2.0	150	200	50	0.12	150	7

POWER MODULES - THYRISTOR / THYRISTOR. THYRISTOR / DIODE

Type No.	$I_{T(AV)}$	@ T_c	V_{RRM} RANGE	I_{TSM}	V_{TM}	@ I_{TM}	V_o	r	V_{GT}	I_{GT}	dv/dt	di/dt	R_{thJC}	R_{thcs}	T_j Max	Ref.Fig.
	$I_{F(AV)}$	$^{\circ}C$	V	I_{FSM}	V_{FM}	I_{FM}	$T_j=T_j$ max	$m\Omega$	V	mA	V/ μ Sec	A/ μ Sec	$^{\circ}C/W$	$^{\circ}C/W$	$^{\circ}C$	
	A			A	V	A	V									
IRK-26	27	85	400 to 1600	595	1.95	85	0.91	12.4	2.5	150	500	100	0.310	0.10	125	1
IRK-41	45	85	400 to 1600	850	1.81	141	0.90	6.58	2.5	150	500	100	0.230	0.10	125	1
IRK-56	60	85	400 to 1600	1310	1.54	188	0.81	3.35	2.5	150	500	100	0.200	0.10	125	1
IRK-71	75	85	400 to 1600	1665	1.59	235	0.76	2.98	2.5	150	500	100	0.165	0.10	125	1
IRK-91	95	85	400 to 1600	1785	1.58	298	0.78	5.00	2.5	150	500	100	0.135	0.10	125	1
IRK-105	105	85	400 to 1600	1785	1.64	330	0.80	2.37	2.5	150	500	100	0.135	0.10	125	1
IRK-136	135	85	400 to 1600	3200	1.66	424	0.98	1.62	3.0	200	500	100	0.200	0.035	125	2
IRK-142	140	85	400 to 1600	4750	1.32	440	1.14	1.29	3.0	200	500	100	0.170	0.035	125	2
IRK-162	160	85	400 to 1600	5100	1.26	503	0.88	1.20	3.0	200	500	100	0.170	0.035	125	2
IRK-170	170	85	400 to 1600	5100	1.60	534	0.89	1.34	3.0	200	500	100	0.170	0.020	125	3
IRK-230	230	85	400 to 1600	7500	1.59	722	1.03	0.77	3.0	200	500	100	0.125	0.020	125	3
IRK-250	250	85	400 to 1600	8500	1.44	785	0.97	0.60	3.0	200	500	100	0.125	0.020	125	3
IRK-280	280	79	400 to 2200	7500	1.55	750	0.90	0.75	3.0	200	500	100	0.110	0.020	125	3
IRK-330	330	85	400 to 1800	8000	1.44	1036	0.80	0.45	2.0	200	500	100	0.110	0.020	125	3
IRK-500	540	85	400 to 1800	15000	1.60	1500	0.92	0.24	3.0	200	500	100	0.062	0.020	125	4
IRK-570	570	85	400 to 1800	15500	1.44	1700	0.78	0.20	3.0	200	500	100	0.069	0.020	125	4
IRK-650	650	85	1000 to 1200	14000	1.40	1978	0.85	0.10	2.5	250	500	100	0.065	0.020	125	4
IRK-715	715	85	1000 to 1800	28000	1.45	2512	0.85	0.20	2.5	250	500	100	0.050	0.016	125	5
IRK-800	800	78	1000 to 1800	28000	1.45	2512	0.85	0.20	2.5	250	500	100	0.050	0.016	125	5
IRK-1000	1000	77	1000 to 1200	32000	1.25	3140	0.90	0.04	2.5	250	500	100	0.050	0.016	125	5

Note: dv/dt 1000v/us is available on request.

HIGH VOLTAGE - THYRISTOR / THYRISTOR. THYRISTOR / DIODE MODULES

IRK136	130	85	1400-2600	3200	1.66	408	0.98	1.62	3.03	200	500	100	0.2	0.035	125	2
IRK160	160	85	2000-3600	4000	2.6	1000	1.2	2.3	2	200	500	100	0.125	0.04	125	3
IRK185	185	85	1500-3000	7500	2.6	1000	1.14	0.78	2	200	500	100	0.125	0.04	125	3
IRK240	240	85	2800-3600	5400	3.43	1200	1.17	1.7	2	200	500	100	0.078	0.02	125	4



HIGH POWER MODULES

PHYSICAL DIMENSIONS

MODULE CIRCUITS

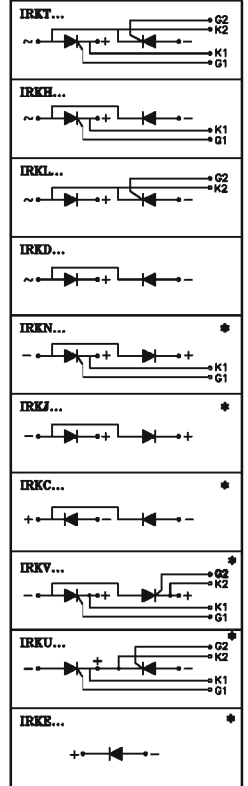
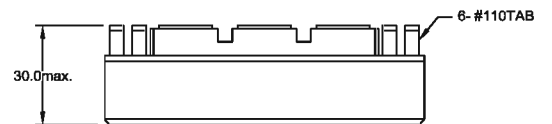
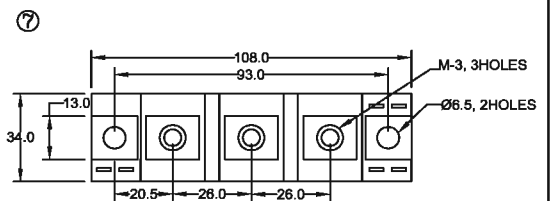
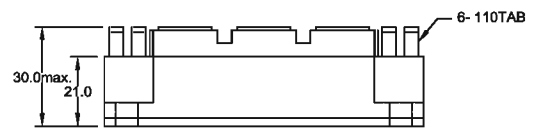
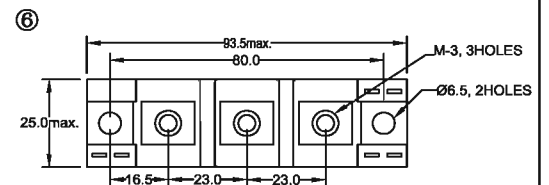
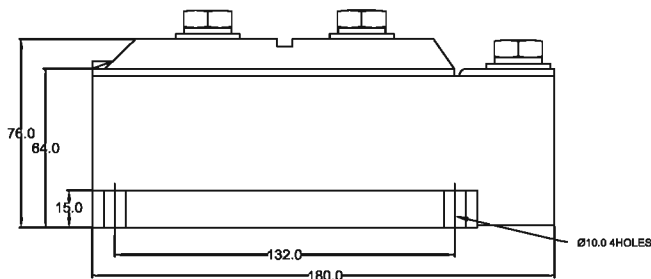
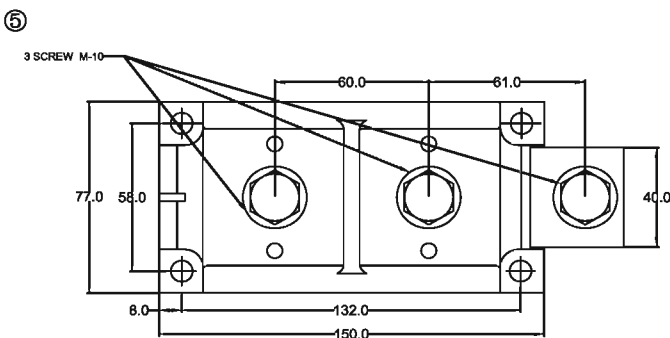
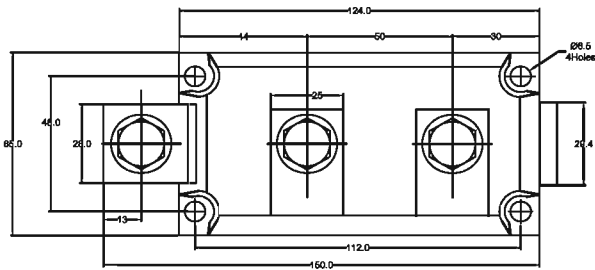
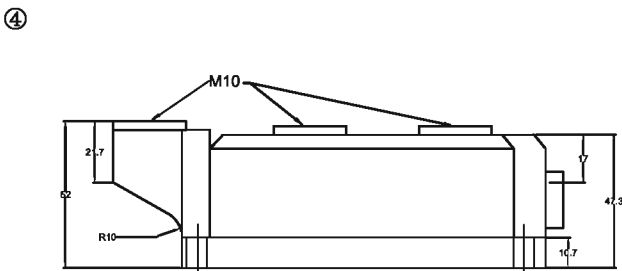
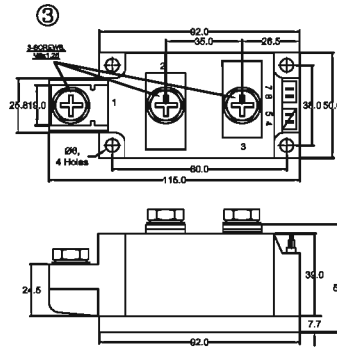
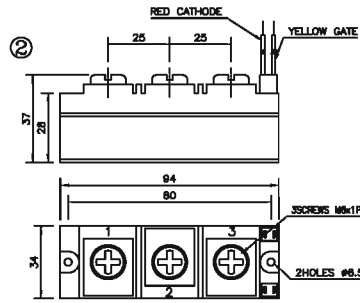
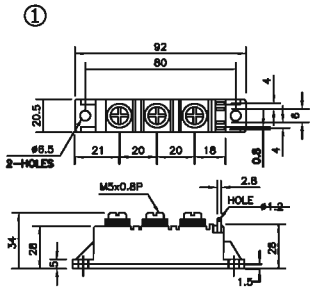

* ON REQUEST

DIODE BRIDGE RECTIFIER - SINGLE PHASE

Type No.	$I_{O(AV)}$	V_{FM}	$@I_{FM}$	$@T_{amb}$	Voltage Range	I_{FSM}	T_j max	Physical Dimension Ref.Fig.
	A	v	A	$^{\circ}C$		A	$^{\circ}C$	
26MB	25	1.10	40	65	200-1600	330	150	1
36MB	35	1.20	55	60	200-1600	400	150	1
51MB	50	1.10	55	60	200-1600	450	150	1

DIODE BRIDGE RECTIFIER - THREE PHASE

Type No.	$I_{O(AV)}$	V_{FM}	$@I_{FM}$	$@T_{amb}$	Voltage Range	I_{FSM}	I^2t	T_j max	Physical Dimension Ref.Fig.
	A	v	A	$^{\circ}C$		A	A ² Sec	$^{\circ}C$	
26MT	25	1.26	40	70	200-1600	360	635	150	2
36MT	35	1.19	40	60	200-1600	475	1130	150	2

ULTRA FAST RECOVERY DIODE MODULE

Type No.	$I_{F(AV)}$	$@T_C$	V_{RRM} RANGE	I_{FSM}	V_{FM}	$@I_{FM}$	trr IFM=100A, VR=200V di/dt=100A/us ns	$R_{th JC}$	T_j	Physical Dimension Ref.Fig.
	A	$^{\circ}C$	V	A	V	A		$^{\circ}C/W$	$^{\circ}C$	
RIRP200..F	200	100	200 - 400	2000	1.3	200	90	0.320	150	3
RIRP300..F	300	100	200 - 400	2500	1.75	300	90	0.320	150	3
RIRP400..F	400	100	200 - 400	2500	1.95	400	90	0.320	150	3

DIODE BRIDGE RECTIFIER - SINGLE PHASE

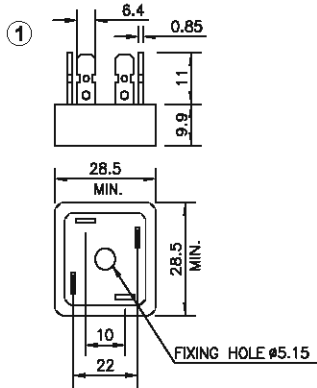

DIODE BRIDGE RECTIFIER - THREE PHASE

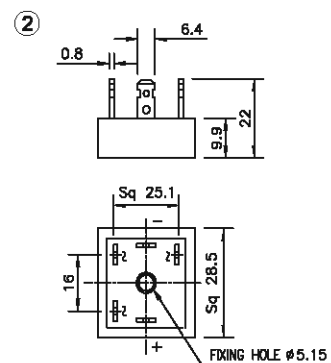

ULTRA FAST RECOVERY DIODE MODULE

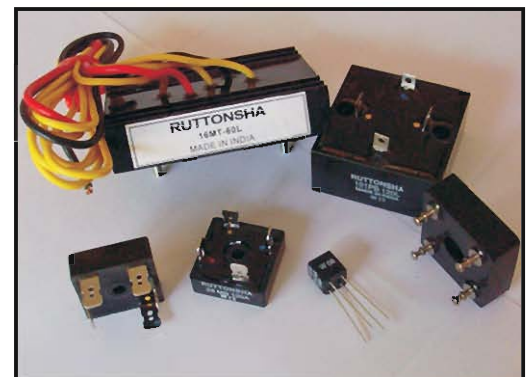
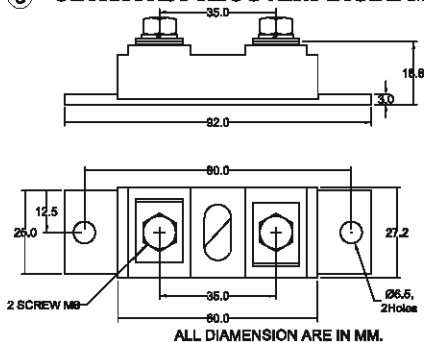

SINGLE PHASE DIODE BRIDGE MODULE

Type No.	Voltage Range	$I_{O(AV)}$	T_c	V_{FM} Per Diode	$@I_{FM}$	I_{FSM} 10ms	V_O r_o $T_J = T_J \text{ max}$		R_{th-jc}	$T_J - \text{max}$	V_{ins}	Fig.
	V	A	$^{\circ}C$	V	A	A	V	m Ω	$^{\circ}C/W$	$^{\circ}C$	V	
RI 8BU30	400 - 1800	30	110	1.3	80	370	0.85	12	0.545	125	2500	1
RI 8BU60	400 - 1800	60	88	1.6	150	1000	0.85	5	0.300	125	2500	1
RIBU52	400 - 1800	50	99	1.8	150	500	0.85	8	0.375	150	2500	2
RIBU72	400 - 1800	70	101	1.6	150	750	0.85	5	0.275	150	2500	2
RI 9BU25	400 - 1800	30	110	1.3	80	370	0.85	12	0.250	125	2500	3
RI 9BU55	400 - 1800	52	100	1.75	75	370	0.85	12	0.200	125	2500	3

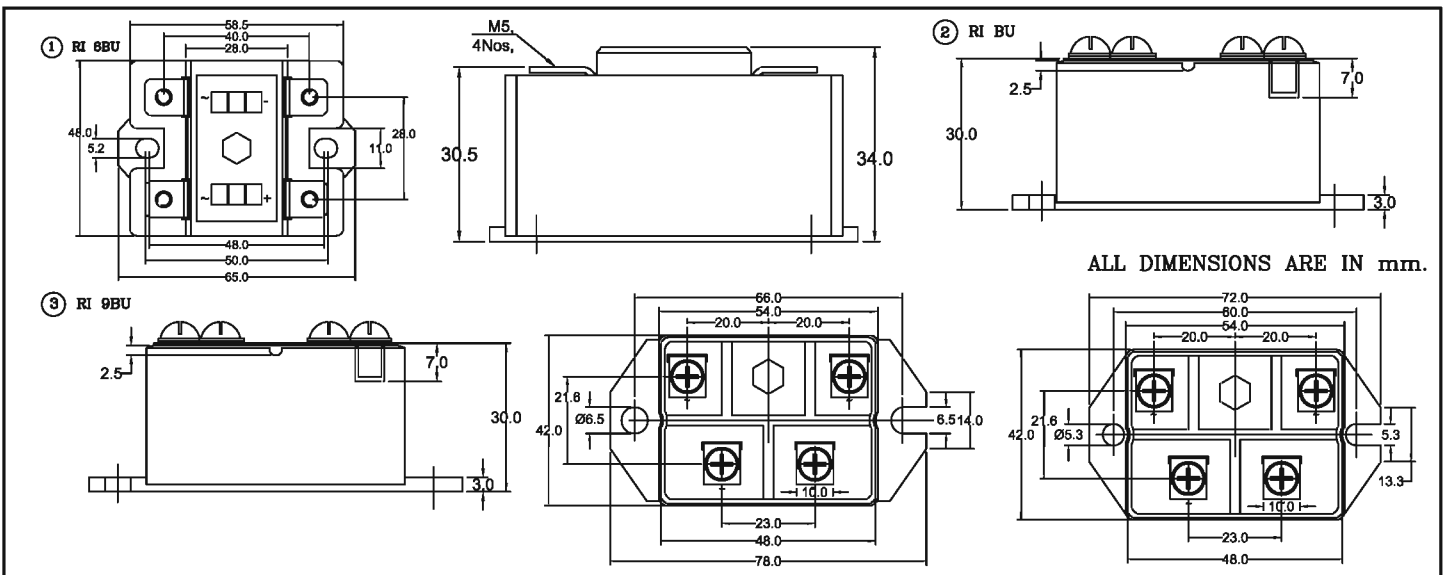

SINGLE PHASE HALF CONTROLLED BRIDGE RECTIFIER MODULE

Type No.	$I_{T(AV)}$	TC	V_{RRM}	I_{TSM}	V_{TM} Per SCR	I_{TM}	V_{GT}	I_{GT}	dv/dt	di/dt	R_{th-jc}	T_J Range	Fig.
			Range	10ms	Per Diode								
			V	A	V								
RI8BKW	41	88	800-1400	470	2.3	75	2.0	60	500	150	1	-40 to 125	1
RI8BKW	61	85	800-1400	470	2.3	75	2.0	60	500	150	1	-40 to 125	1

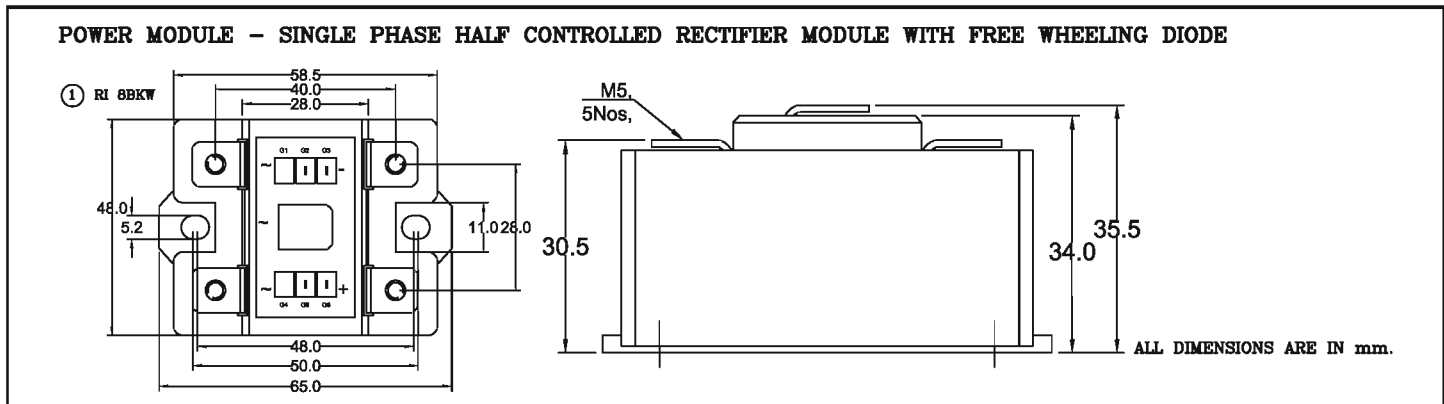

THREE PHASE DIODE BRIDGE MODULES

Type No.	Voltage Range	$I_{O(AV)}$	T_c	V_{FM}	@ I_{FM}	I_{FSM}	V_O	r_o	R_{th-jc}	T_j max	Vins	Fig.
	V	A	°C	Per Diode	10ms	A	V	mΩ	°C/W	°C	V	
RI 8TU30	400-1800	40	90	1.3	80	370	0.85	12	0.43	125	2500	1
RI 8TU60	400-1800	60	102	1.6	150	1000	0.85	5	0.167	125	2500	1
RI 8TU100	400-1800	100	93	1.35	150	1150	0.85	5	0.14	125	2500	1
RITU62	400-1800	60	110	1.8	150	500	0.85	8	0.25	150	2500	2
RITU82	400-1800	80	110	1.6	150	750	0.85	5	0.183	150	2500	2
RI 9TU25	400-1800	25	110	1.3	80	370	0.85	12	0.25	125	2500	3
RI 9TU55	400-1800	55	100	1.75	75	370	0.85	12	0.2	125	2500	3
RI 9TU110	400-1800	110	100	1.35	150	1150	0.85	4	0.15	150	2500	3
RITU160	400-1800	160	100	1.65	300	1800	0.85	3	0.11	150	2500	4

THREE PHASE DIODE MODULE

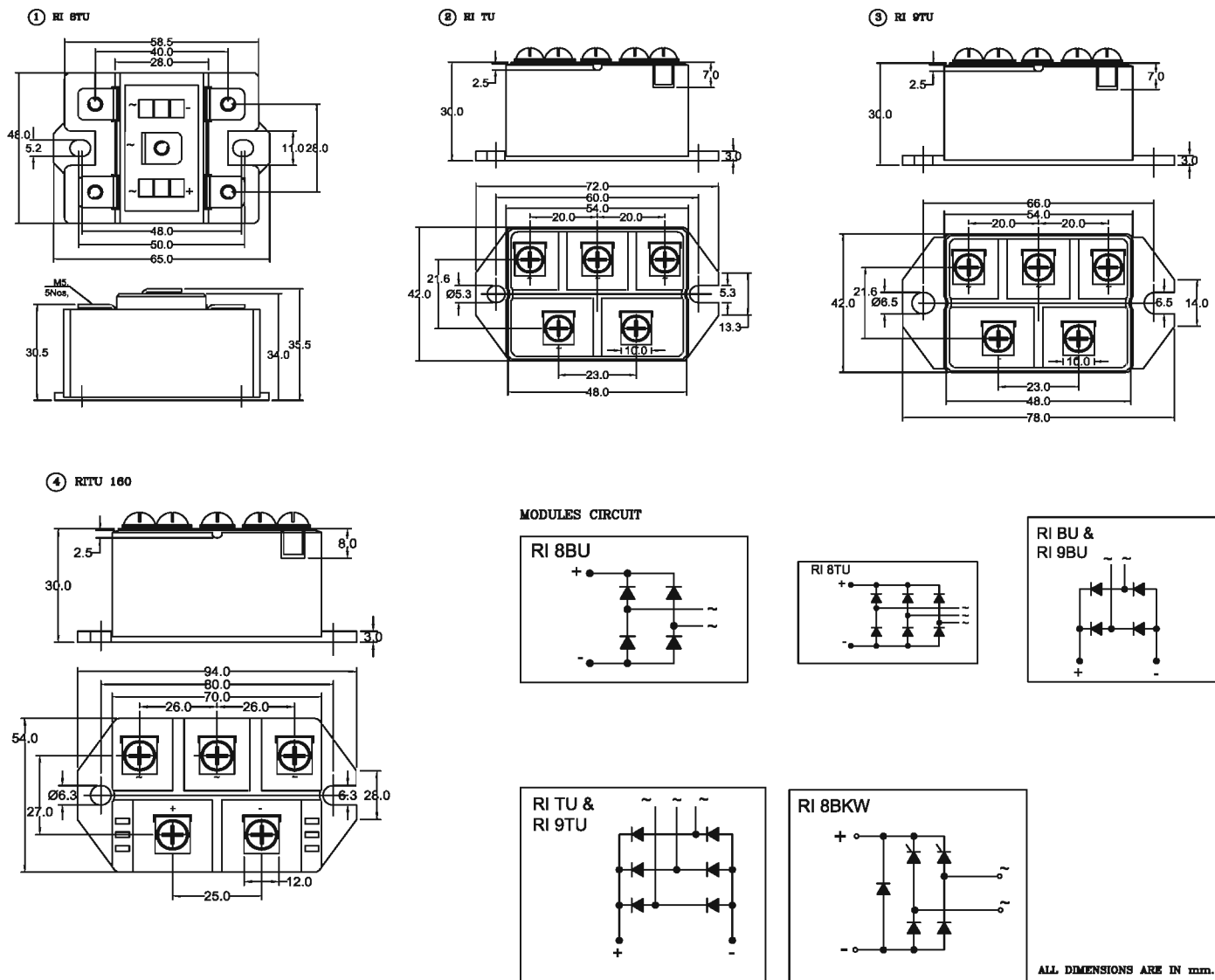

THYRISTOR STACK (B6C)

Sr. No.	Device Type	I/P Voltage	Class -1	Class -2	Class -4	Class -5	Class -6	Stack Size in mm (W x D x H)
			100 % Cont.	150 % For 1 Minute	125% for 2 hrs 200% for 10 Secs	150% for 2 hrs 200% for 1 Min	150% for 2 hrs 300% for 1 Min	
1	600 PE 16	450 V	800 A	560 A	440 A	410 A	280 A	1000 x 600 x 900
2	700 PE 18	450 V	860 A	600 A	475 A	450 A	340 A	1000 x 600 x 900
3	700 PE 18	500 V	1010 A	710 A	575 A	525 A	360 A	1000 x 600 x 900
4	1000 PB 16	450 V	1375 A	975 A	800 A	725 A	500 A	1000 x 600 x 900
5	1200 PK 18	500 V	1675 A	1225 A	1025 A	900 A	640 A	1000 x 600 x 900
6	1200 PK 18	500 V	2090 A	1540 A	1325 A	1125 A	800 A	1000 x 600 x 900
7	1700 PK 18	500 V	2350 A	1740 A	1360 A	1275 A	910 A	1000 x 600 x1000
8	2500 PM 18	500 V	2990 A	2225 A	1770 A	1625 A	1175 A	1000 x 600 x1000
9	3500 PQ 18	550 V	3675 A	2850 A	2325 A	2050 A	1525 A	1000 x 600 x1000
10	3500 PQ 22	700 V	3550 A	2375 A	2225 A	1975 A	1475 A	1000 x 600 x1000
11	2400 PR 22	750 V	1740 A	1275 A	1100 A	925 A	670 A	1000 x 600 x1000
12	2800 PR 22	750 V	2475 A	1850 A	1470 A	1350 A	975 A	1000 x 600 x1000
13	2800 PR 32	1000 V	2350 A	1450 A	1400 A	1275 A	925 A	1000 x 600 x1000

Diode Stack (B6U)

Sr. No.	Device Type	I/P Voltage	Class -1 100 % Cont.	Class -2 150 % For 1 Minute	Recommended Panel Size in mm (W x D x H)
1	R 650 16	415 VAC	1200 A	800 A	1000 x 600 x 900
2	R 1200 160	415 VAC	1800 A	1200 A	1000 x 600 x 900
3	R 2000 K 60	415 VAC	2500 A	1800 A	1000 x 600 x 900
4	R 3000 K 200	660 VAC	3000 A	2000 A	1000 x 600 x 900

Note : - Current Rating are valid for forced cooling of 5 mtrs/ Sec air outlet and ambient temp. 45°C Provided with suitable Fuses & Heatsink

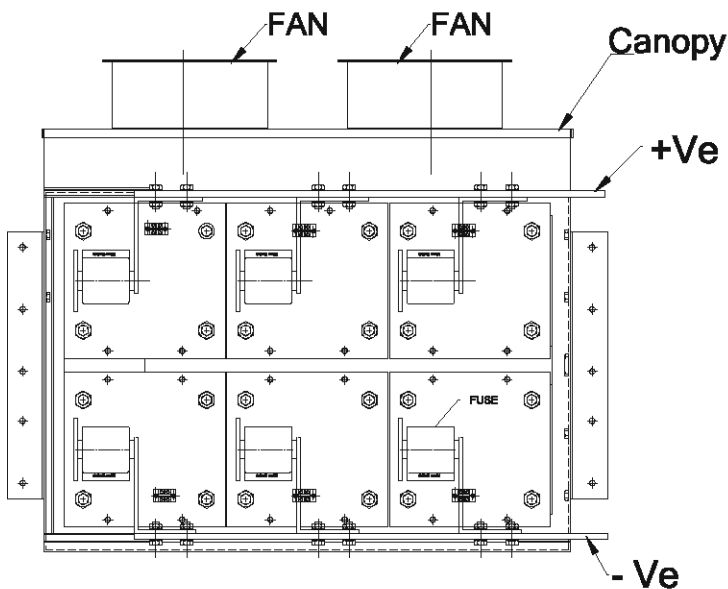

WELDING RECTIFIER

Sr. No.	Device Type	In	V _{out}	Duty	Air Speed	V _{RRM}	Dimensions are mm
		(A)	(V)	Cycle	(m/s)	(V)	
1	S 240	240	100	60 %	4	400	Fig 1
2	S 400	400	100	60 %	4	400	Fig 1
3	S 600	600	100	60 %	4	400	Fig 1
4	S 800	800	100	60 %	4	400	Fig 1

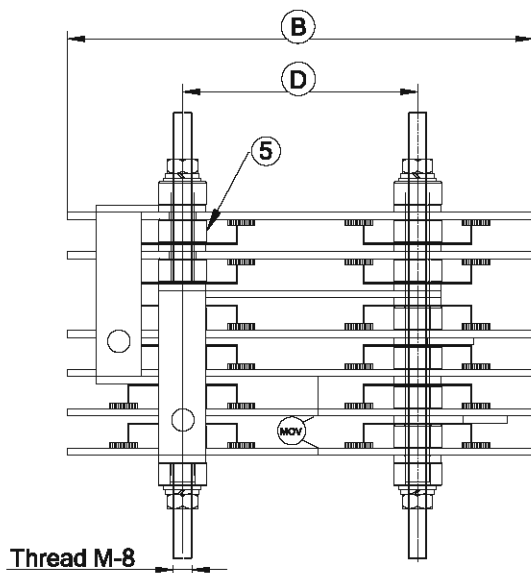
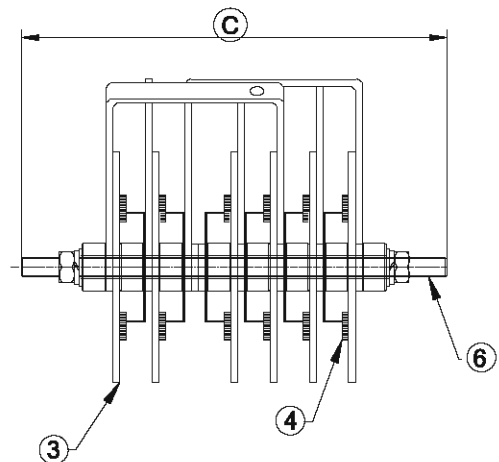
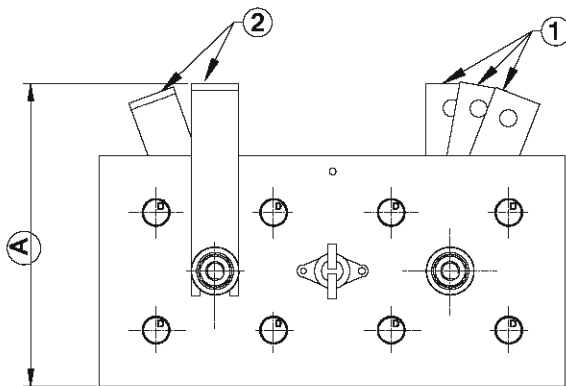
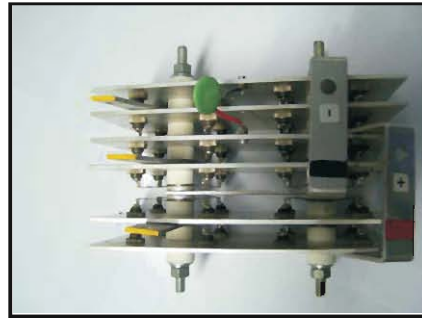
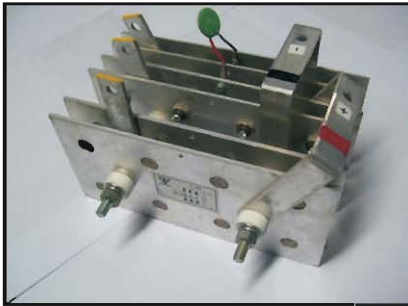

Fig - 1

Sr.No.	Description
01	AC Busbar (R,Y,B)
02	DC Busbar (+Ve, -Ve)
03	Alu. Heatsink
04	Auto Diode
05	Ceramic Bush
06	Fixing Stud

SR-NO	TYPE	(A)	(B)	(C)	(D)
01	S 240	130	200	190	100
02	S 400	130	200	190	100
03	S 600	135	200	295	100
04	S 800	135	200	295	100

WATER COOLED ASSEMBLIES

Sr.No.	Device Type	V _{DRM} / V _{DRM}	I _{RMS} / T _{WATER}	I _{TSM} Sine wave 10 ms	Dimension are mm
		(V)	(A / °C)	(kA)	
1	W1C 600-PA	1600 V	600/ 40	5-6	FIG 1
2	W1C 1000-PE	1600 V	1000/ 40	9-0	FIG 1
3	W1C 1300 PB	1600 V	1300/ 40	17-8	FIG 1
4	W1C 1500-PK	1600 V	1500/ 40	23-6	FIG 1

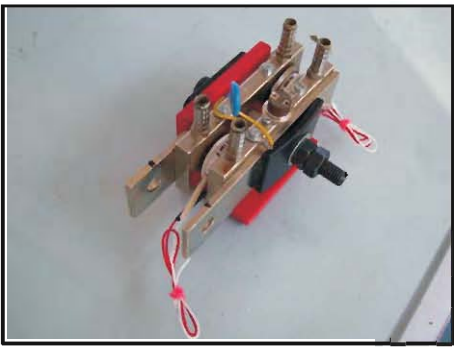

Water Flow Rate - 4.5 L/ min
 Max. Water Pressure - 10 Bar
 Note : - dv/ dt - 500 V/ μ (Higher dv/dt Is available on request)

SR.NO.	TYPE	(A)	(B)	(C)	(D)	(E)	(F)	(G)
01	W1C 600-PA	50	48	122-5	205	90-0	110-8	51
02	W1C 1000-PE	51	54	122-5	205	90-0	110-8	51
03	W1C 1300 PB	63	59-5	132-0	205	90-0	110-8	51
04	W1C 1500-PK	64	59-5	150-0	215	99-0	120-0	63-2

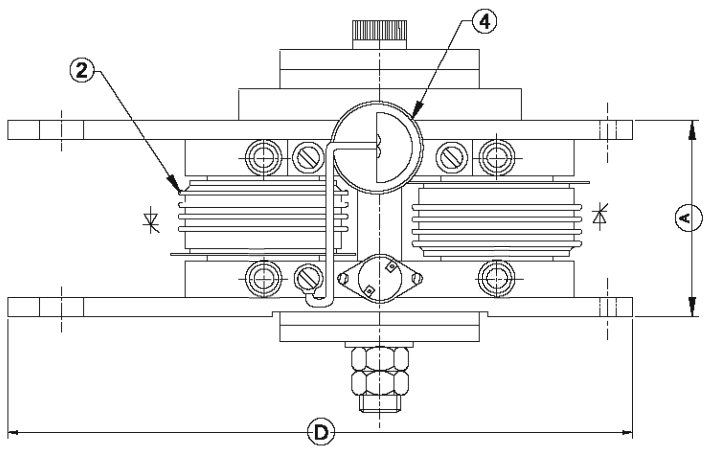
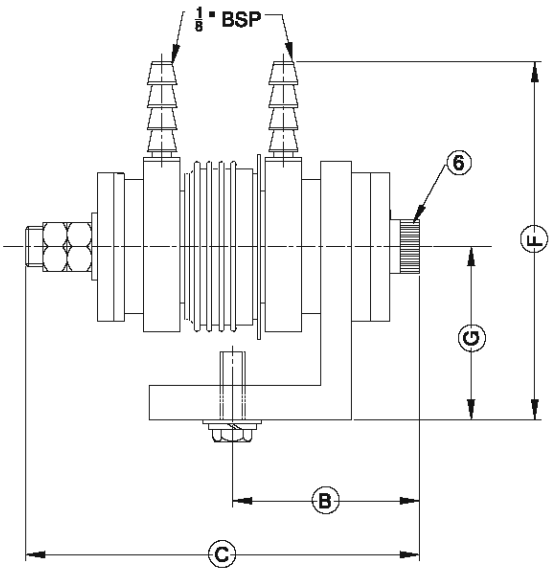
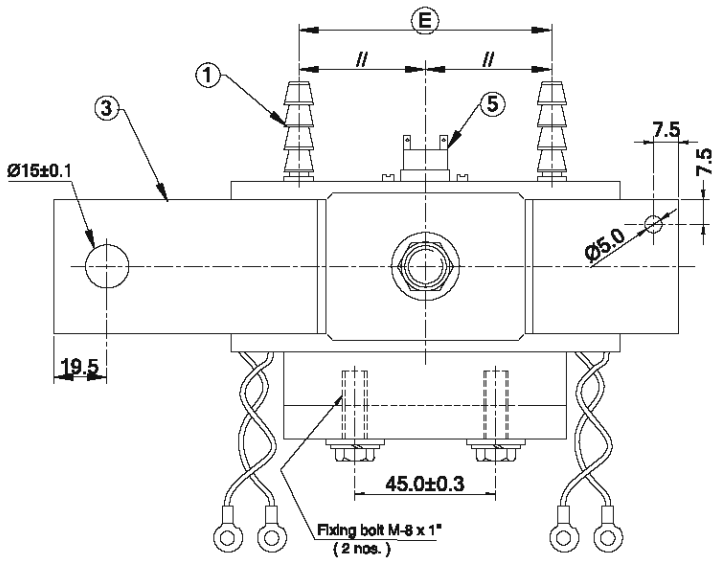

Sr.No.	Description
01	Water Cooled Heat-Sink
02	Hockey puk
03	Connecting Copper Busbar
04	Varistor
05	Thermal switch
06	Fixing bolt

Fig - 1

All Dimensions in M.M.

ISOLATED WATER COOLED MODULE ASSEMBLIES

Fig - 1

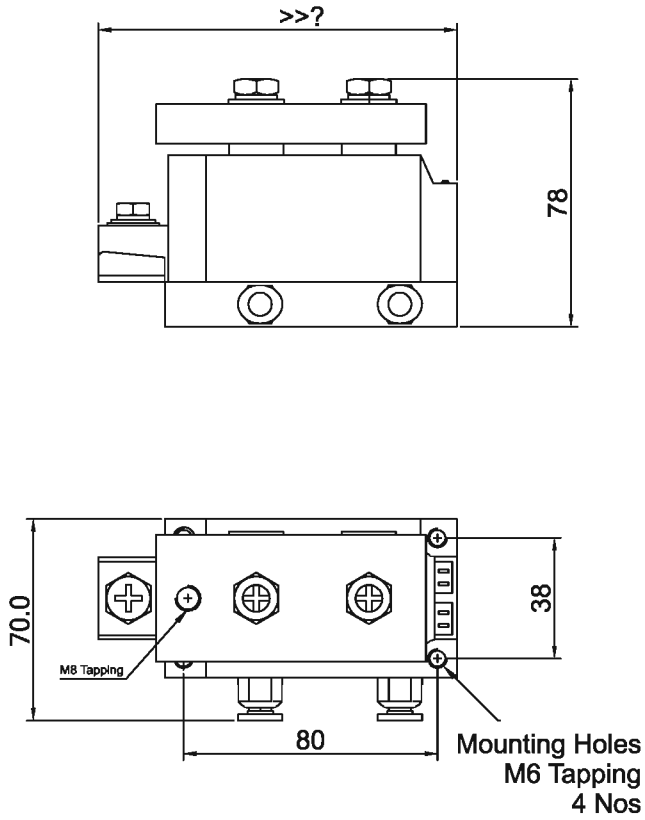
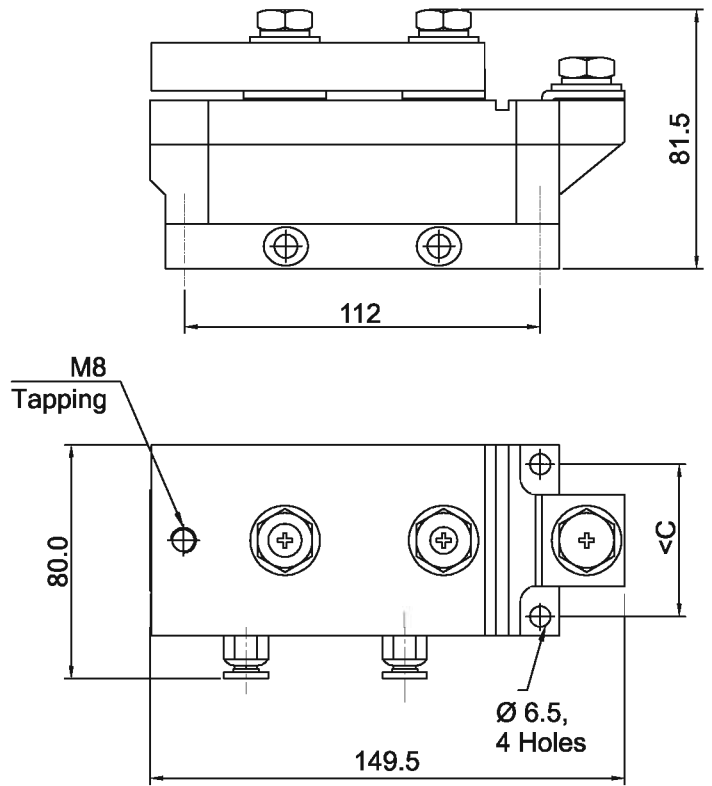

Fig - 2



Isolated Water Cooled Module Assemblies

Sr. No.	Module Type	V_{DRM} / V_{DRM}	I_{RMS} / T_{WATER}	I_{TSM} Sine wave 10 ms	Dimension are mm
		(V)	(A/°C)	(kA)	
1	W1CI - 550 - 16	1600 V	550/ 40	5.6	Fig 1
2	W1CI - 850 - 16	1600 V	850/ 40	9.0	Fig 1
3	W1CI - 1200 - 16	1600 V	1200/ 40	12.5	Fig 2

IGBT STACK



132 KW

3 Phase half Controlled and PWM 3 Phase inverter in Thermal Stack for AC Motor driver

DC Link - 560V \pm 10%
Voltage 3 x 400V - (1Hz to 50 Hz)
& nominal - 230 Amps RMS
of Switch - 2.4 KHz
3 x 8800 μ F x 800V DC Link



20 KVA UPS SYSTEM

with 3 \emptyset & 1 \emptyset AC Output & with DC link

SR.NO.	Vin/ Vdc Link	O/P ACV	O/P ACA	KVA	Height	Width	Depth	IGBT IN Parallel Per arms	Heatsink	Driver
01	400/540	415	50	36	260	300	250	1 x 2MBI 75/ 120	1xAD80/250	RUTTONSHA
02	400/540	415	100	72	420	340	560	1 x 2MBI 150/120	1xRIR22/300	RUTTONSHA
03	400/540	415	150	108	420	340	820	2 x 2MBI 200/120	1xRIR22/600	CONCEPT
04	400/540	415	200	144	420	340	820	2 x 2MBI 200/120	1xRIR22/600	CONCEPT
05	400/540	415	250	180	900	600	550	3 x 2MBI 200/120	3xRIR22/300	CONCEPT
06	400/540	415	300	216	1000	600	550	3 x 2MBI 200/120	3xRIR22/400	CONCEPT
07	400/540	415	400	288	1100	600	550	4 x 2MBI 300/120	3xRIR22/400	CONCEPT
08	400/540	415	500	359	1100	600	550	4 x 2MBI 400/120	3xRIR22/400	CONCEPT

PRODUCT RANGE

SEMICONDUCTOR DEVICES

- Diodes – Standard Recovery (Stud-Flat Base)
6 Amp to 860 Amp – 400 PIV to 4600 PIV
- Diodes – Fast Recovery (Flat Base)
6 Amp to 150Amp – 400 PIV to 1200 PIV
- Diodes – Standard Recovery (Capsule Type)
650Amp to 12000 Amp – 400 PIV to 6000 PIV
- Diodes – Fast Recovery (Capsule Type)
430 Amp to 1650 Amp – 400 PIV to 3000 PIV
- SCR Phase Control (Stud/Flat Base)
16 Amps to 400 Amp – 400 PIV to 1600 PIV
- SCR Inverter (Stud)
85 Amps to 300 Amp – 400 PIV to 1200 PIV
- SCR Phase Control (Capsule)
400 Amp to 8500 Amps – 600 PIV to 7000 PIV
- SCR Inverter (Capsule)
330 Amp to 2550 Amps – 600 PIV to 2800 PIV
- Modules (SCR/SCR, SCR/Diodes, Diode/Diode)
25 Amp to 1000 Amps, 400 PIV to 2000 PIV
- Three Thyristor Modules (Non Isolated)
60 Amps to 200 Amps 400 PIV
- Single Phase Moulded Bridge
1 Amp to 100 Amps, 400 PIV to 1600 PIV
- Three Phase Moulded Bridges
25 Amps to 160 Amps, 400 PIV to 1600 PIV
- Three Phase Module Controlled Bridges
55 Amps to 110 Amps, 800 PIV to 1600 PIV
- Single Phase Module Controlled Bridges
25 Amp and 40 Amps, 400 PIV to 1200 PIV
- Button type Diode Welding Stack
- Capsule type Diode Welding Assembly
- Converter grade Thyristor Welding Assembly
- Water cooled A/c Switches
- Surge Suppressors
- High Power Diode/Thyristor Stacks

POWER EQUIPMENTS

● Battery Chargers

Upto 220 Volts, 2000 AH. Higher range as per customer's requirement. The battery Charger range includes Conventional Chargers, Float Chargers, Boost Chargers, Traction Chargers.

● Rectifier Equipments

Upto 1000 KW. Higher capacity rectifier supplied as per customer's specifications. Range includes rectifiers for electrochemical processes, electroplating, battery plates forming and other industrial applications.

● Railway Equipments

DC Traction substation 750 – 1500 V, 3 MW, Electric Loco Rectifiers, Rectifiers for EMUs & DMUs.

● Invertors

5 kVA to 50 kVA for industrial and elevator applications.

● DC Drive Rectifiers

200 Amps. to 8000 Amps. Upto 1000 VDC.